

2021

## MAGNETIC FILTER SCRUBBER SERIES



SOLVING TOMORROW'S CHALLENGES TODAY.

©2021 One Eye Industries Inc. All rights reserved.

[www.hubame.com.mx](http://www.hubame.com.mx) | [marketing@hubame.com.mx](mailto:marketing@hubame.com.mx) | Teléfono (81) 8000 7600

# Hubame

Distribuidor Autorizado

# ONE EYE INDUSTRIES SCRUBBER SERIES



[www.hubame.com.mx](http://www.hubame.com.mx) | [marketing@hubame.com.mx](mailto:marketing@hubame.com.mx) | Teléfono (81) 8000 7600

# Hubame

Distribuidor Autorizado

# SCRUBBER SERIES

## DESCRIPTION

Magnetic filter scrubbers employ a magnetic filter element in a specialty housing designed to operate with minimal flow restriction and maximum fluid exposure for high-efficiency filtration. Flow is regulated by the diameter of the inlet-outlet supply pipe as well as fluid velocity. These systems install on suction and return lines of high-pressure and low-pressure applications.

## BENEFITS

- » Minimal flow restriction allows for suction line installation and pump protection.
- » High holding capacity allows for extended planned maintenance periods.
- » Acts as an effective predictive maintenance tool if contamination is collected and analyzed to determine sources of equipment component wear.

## EFFICIENCY

Magnetic Filter Element	Ferrous Contamination	Captures ferrous wear particles down to 4 $\mu$ and below with up to 95+% efficiency.
	Non-ferrous Contamination	Non-ferrous particles are magnetically captured because of cross-contamination from static charge or embedded ferrous particles.

## OPERATING PARAMETERS

Pressure / Temperature Rating	Standard	< 10.3 bar (150 psi) @ < 105° C (221° F)
	High Heat	< 34.4 bar (500 psi) @ < 204.4° C (400° F)
Viscosity Rating	Standard	< 680 cSt
	Low Viscosity	< 2,000 cSt
Bypass Settings	Continuous filtration with no internal bypassing	

## CLEANING

Magnetic Filter Element: Remove the contamination by wiping downward with a lab cloth or rubber glove.

Use the magnetic filter element as a predictive maintenance tool by removing contamination with a lab cloth or rubber glove and depositing it into a sample jar. Send the contamination for analysis to determine the source of equipment component wear and prevent system failure.

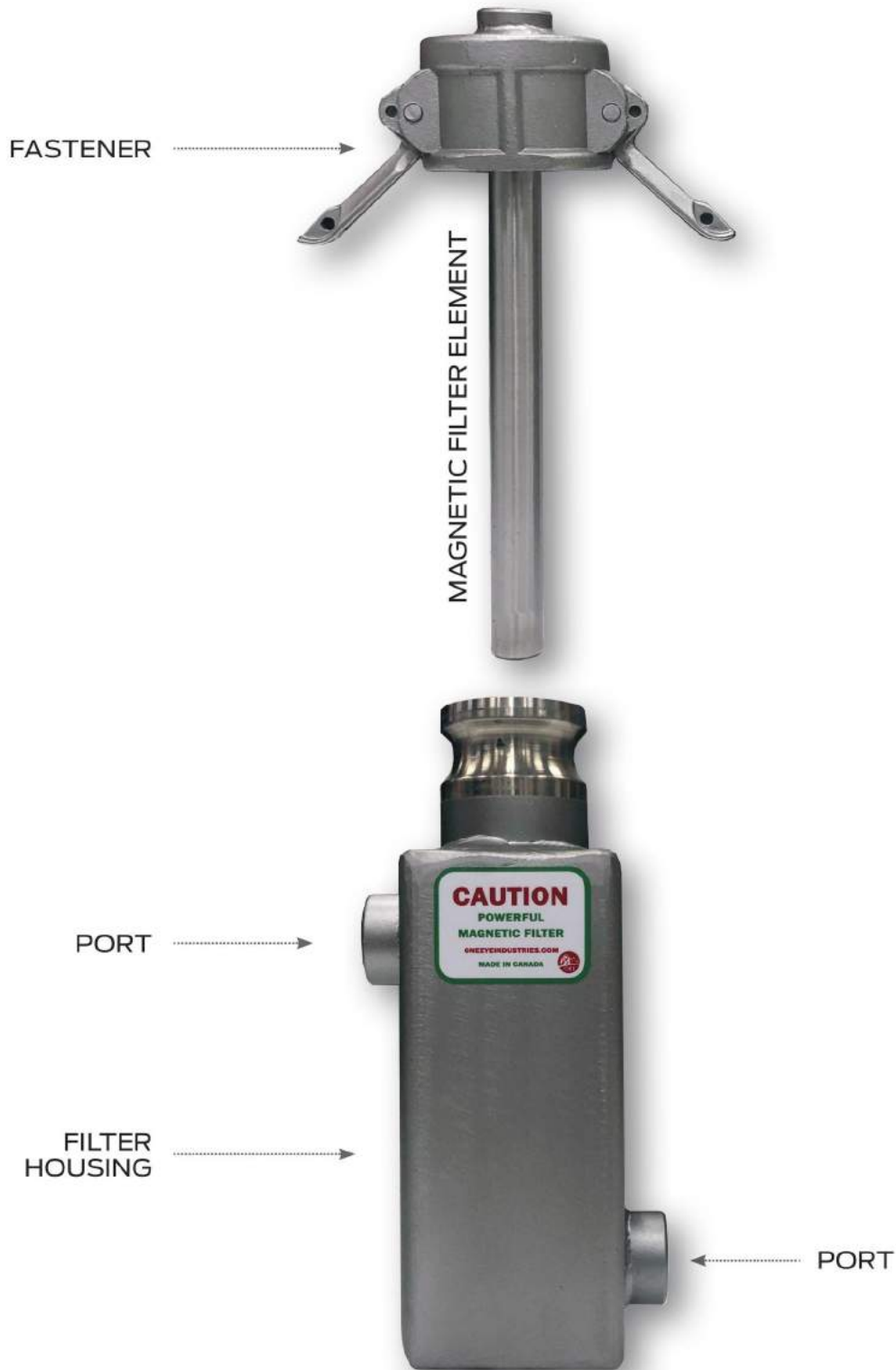

Standard design with 180° offset ports

[www.hubame.com.mx](http://www.hubame.com.mx) | [marketing@hubame.com.mx](mailto:marketing@hubame.com.mx) | Teléfono (81) 8000 7600

**Hubame**

Distribuidor Autorizado



# STANDARD SCRUBBER SPECIFICATIONS

## MATERIALS

Magnetic Filter Element	Rare-earth magnets configured in a patented radial field design.	
Filter Housing, Drain Plugs, End Caps, Mounts	Standard	Stainless Steel
	Specialty Materials	» Monel » Other alloys available
Seals	Standard Heat	Buna
	High Heat	Viton
	Sub-zero	EDPM

## CONFIGURATIONS

Magnetic Filter Element	Quantities	» Single » Dual	» Dual Inline » Triple	» Quadruple
	Lengths	» 9"	» 12"	» 24"    » 36"
Housings	Square	< 10.3 bar (150 psi)		
	Round	< 34.4 bar (500 psi)		
Fasteners	Cam-lock	< 10.3 bar (150 psi)		
	ORB, Flange	< 34.4 bar (500 psi)		
Ports	» Inline	» Parallel Ports	» Upper housing » Lower housing	
	» Offset	» 0° Offset » 90° Offset	» 180° Offset » 270° Offset	
	» Multi-port	» Manifold		

## INSTALLATION

Port Size <i>Custom sizes available</i>	1/2" - 2 1/2"			
Port Type	» NPT » ORB	» CD61 » CD62	» BSPT » BSPP	» Flange
Mount Type	» Inline » Vertical	» Horizontal		
Element Clearance	Housing length + 4"			

## LIMITED WARRANTY

Magnetic Filter Element	3 years
Housing and Components	1 year

## SERVICE LIFE

Magnetic Filter Element	18+ years
-------------------------	-----------

www.hubame.com.mx | marketing@hubame.com.mx | Teléfono (81) 8000 7600



Distribuidor Autorizado

# SCRUBBER SERIES SPECIFICATIONS

	DESCRIPTION	PART NUMBER	PRESSURE RATING	TEMP. RATING	HOUSING SIZE	MAGNETIC FILTER ELEMENT	
LOW PRESSURE	<i>OEI standard magnetic filter scrubber is designed with a square housing, typically with a camlock fastener. These units install with multiple port size, location, and fitting options.</i>	5SC349S	< 10.3 bar (150 psi)	105° C (221° F)	3" L x 3" W x 9" H	¾" OD	
		5SC12S	< 10.3 bar (150 psi)	105° C (221° F)	4" L x 4" W x 12" H	1" OD	
		5SC24S	< 10.3 bar (150 psi)	105° C (221° F)	4" L x 4" W x 24" H	1" OD	
MEDIUM PRESSURE	<i>Fluid applications requiring pressures over 150 psi are designed with a round housing and ORB, or flange fastener.</i>	5SC349RORB	< 34.4 bar (500 psi)	105° C (221° F)	3" OD x 9" H	¾" OD	
		5SC12RORB	< 34.4 bar (500 psi)	105° C (221° F)	4" OD X 12" H	1" OD	
		5SC24RORB	< 34.4 bar (500 psi)	105° C (221° F)	4" OD x 24" H	1" OD	
HIGH PRESSURE	<i>Designed for high pressure applications up to 5000 psi.</i>	5SMP	< 206.8 bar (3000 psi)	75° C (167° F)	3 ½" OD x 17" H	1" OD	
		5SHP	< 344.7 bar (5000 psi)	75° C (167° F)	3 ½" OD x 17" H	1" OD	
SPECIALTY	INLINE	<i>With a billet aluminum housing, this scrubber installs inline for low-pressure, light viscosity, low-flow applications.</i>	5ILO4	6.9 bar (100 psi)	105° C (221° F)	2 ¼" OD x 6" H	½" OD
			5ILO5	6.9 bar (100 psi)	105° C (221° F)	2 ¼" OD x 7 ¼" H	¾" OD
			5IL905	6.9 bar (100 psi)	105° C (221° F)	2 ¼" OD x 9 ¼" H	¾" OD
	FUNNEL	<i>This scrubber installs inline on food and material production lines.</i>	4FS#	24.1 bar (350 psi)	121.1° C (250° F)	4" OD x 27" H	1" OD



PART NUMBER		Flow Rate (gpm)					
		30 cSt	110 cSt	220 cSt	460 cSt	680 cSt	1,000 cSt
5SC349S	Single-Pass	8 gpm (30.3 L/min)	7 gpm (26.9 L/min)	6 gpm (22.7 L/min)	5 gpm (18.9 L/min)	3 gpm (11.4 L/min)	NA
	Multi-Pass	30 gpm (113.6 L/min)	30 gpm (113.6 L/min)	15 gpm (56.8 L/min)	10 gpm (37.9 L/min)	5 gpm (18.9 L/min)	NA
5SC12S	Single-Pass	21 gpm (79.5 L/min)	20 gpm (75.7 L/min)	15 gpm (56.8 L/min)	12 gpm (45.4 L/min)	6 gpm (22.7 L/min)	3 gpm (11.4 L/min)
	Multi-Pass	81 gpm (306.6 L/min)	65 gpm (246.1 L/min)	41 gpm (155.2 L/min)	25 gpm (94.6 L/min)	13 gpm (49.2 L/min)	5 gpm (18.9 L/min)
5SC24S	Single-Pass	40 gpm (151.4 L/min)	38 gpm (143.9 L/min)	30 gpm (113.6 L/min)	20 gpm (75.7 L/min)	10 gpm (37.9 L/min)	10 gpm (37.9 L/min)
	Multi-Pass	95 gpm (359.6 L/min)	80 gpm (302.8 L/min)	76 gpm (287.7 L/min)	30 gpm (113.6 L/min)	16 gpm (60.6 L/min)	8 gpm (30.3 L/min)
5SC349RORB	Single-Pass	8 gpm (30.3 L/min)	7 gpm (26.9 L/min)	6 gpm (22.7 L/min)	5 gpm (18.9 L/min)	3 gpm (11.4 L/min)	NA
	Multi-Pass	30 gpm (113.6 L/min)	30 gpm (113.6 L/min)	15 gpm (56.8 L/min)	10 gpm (37.9 L/min)	5 gpm (18.9 L/min)	NA
5SC12RORB	Single-Pass	21 gpm (79.5 L/min)	20 gpm (75.7 L/min)	15 gpm (56.8 L/min)	12 gpm (45.4 L/min)	6 gpm (22.7 L/min)	3 gpm (11.4 L/min)
	Multi-Pass	81 gpm (306.6 L/min)	65 gpm (246.1 L/min)	41 gpm (155.2 L/min)	25 gpm (94.6 L/min)	13 gpm (49.2 L/min)	5 gpm (18.9 L/min)
5SC24RORB	Single-Pass	40 gpm (151.4 L/min)	38 gpm (143.9 L/min)	30 gpm (113.6 L/min)	20 gpm (75.7 L/min)	10 gpm (37.9 L/min)	10 gpm (37.9 L/min)
	Multi-Pass	95 gpm (359.6 L/min)	80 gpm (302.8 L/min)	76 gpm (287.7 L/min)	30 gpm (113.6 L/min)	16 gpm (60.6 L/min)	8 gpm (30.3 L/min)
5SMP	Single-Pass	7 gpm (26.9 L/min)	7 gpm (26.9 L/min)	6 gpm (22.7 L/min)	5 gpm (18.9 L/min)	3 gpm (11.4 L/min)	NA
	Multi-Pass	30 gpm (113.6 L/min)	30 gpm (113.6 L/min)	15 gpm (56.8 L/min)	10 gpm (37.9 L/min)	5 gpm (18.9 L/min)	NA
5SHP	Single-Pass	7 gpm (26.9 L/min)	7 gpm (26.9 L/min)	6 gpm (22.7 L/min)	5 gpm (18.9 L/min)	3 gpm (11.4 L/min)	NA
	Multi-Pass	30 gpm (113.6 L/min)	30 gpm (113.6 L/min)	15 gpm (56.8 L/min)	10 gpm (37.9 L/min)	5 gpm (18.9 L/min)	NA
5ILO4	Single-Pass	2 gpm (7.6 L/min)	NA	NA	NA	NA	NA
	Multi-Pass	4 gpm (15.1 L/min)	NA	NA	NA	NA	NA
5ILO5	Single-Pass	3 gpm (11.4 L/min)	NA	NA	NA	NA	NA
	Multi-Pass	6 gpm (22.7 L/min)	NA	NA	NA	NA	NA
5IL905	Single-Pass	3 gpm (11.4 L/min)	NA	NA	NA	NA	NA
	Multi-Pass	6 gpm (22.7 L/min)	NA	NA	NA	NA	NA
4FS4200	Single-Pass	20 gpm (75.7 L/min)	NA	NA	NA	NA	NA
	Multi-Pass	NA	NA	NA	NA	NA	NA

www.hubame.com.mx | marketing@hubame.com.mx | Teléfono (81) 8000 7600



Distribuidor Autorizado

# CORE TECHNOLOGY

## DESCRIPTION

The patented magnetic filter element attracts ferrous wear particles down to 4 microns and below with up to 95+% efficiency. The magnetic filter element attracts both ferrous and non-ferrous particles. The radial magnetic field design offers incredible holding strength and a high dirt holding capacity.

OEI magnetic filter elements are employed in various housings designed with calculated dwell times for optimal filtration. Magnetic filter elements come in five sizes from 1/2" to 2" outer diameter (OD) (shown below).



1" magnetic filter elements with varying loads of contamination. Dirt holding capacity\*: 3.97 lb-ft.

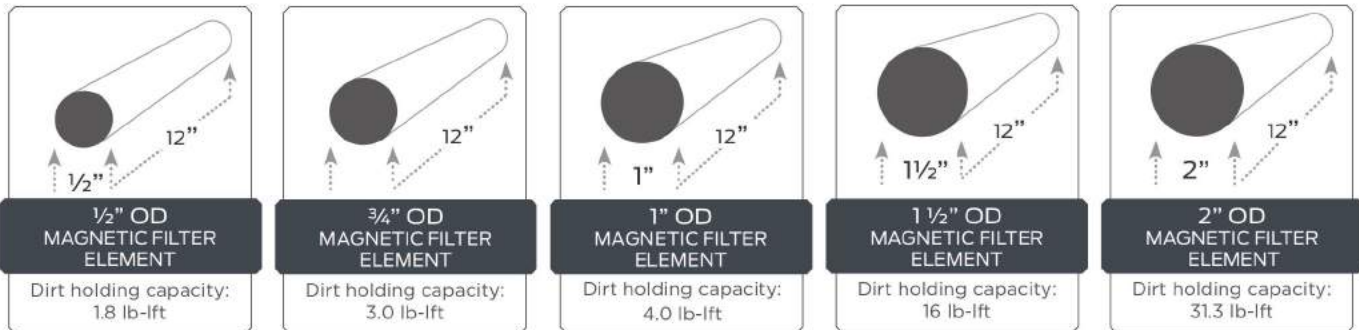

[www.hubame.com.mx](http://www.hubame.com.mx) | [marketing@hubame.com.mx](mailto:marketing@hubame.com.mx) | Teléfono (81) 8000 7600



Distribuidor Autorizado



# CORE TECHNOLOGY BENEFITS

## CLEAN AND REUSE

OEI products are reusable for 18+ years, and require minimal consumables. Conventional filters require frequent, costly changeouts, and disposal.

## PREDICTIVE MAINTENANCE

OEI Magnetic Filter Elements are effective predictive maintenance tools when used for condition monitoring. When removed for inspection, magnetic filter elements will have varying quantities of contamination. Abnormally high quantities of contamination indicate component failure. The composition of contamination will identify which components are stressed, worn, or failing.

Visual analysis of the quantities of wear contamination collected on magnetic filter plugs can determine component failure. Analysis of wear particle compositions and sizes will determine early component wear.

## GOES WHERE NO CONVENTIONAL FILTER HAS GONE BEFORE

OEI magnetic filters can be installed on suction lines to protect pumps without risk of cavitation. Unlike conventional filters, they accommodate space restrictions and unique applications such as splash oil gearboxes, reservoirs, and small coolant lines.

## CAPTURES NON-FERROUS CONTAMINATION

Non-ferrous particles are magnetically captured because of cross-contamination. Particles become statically charged from flow velocity. This charge is a principal force of particle adhesion; iron particles contaminate non-ferrous particles by adhering to their statically charged surface. Another form of cross-contamination occurs when sub-micron iron particles embed in softer non-ferrous particles after abrasive impact.

## PREVENT OXIDIZATION AND VARNISH

OEI effectively removes iron and steel particles under 10 microns that are known to promote oil oxidation because of their catalytic properties. Oxidation can deplete additives that protect against wear, corrosion, sludge, varnish, and viscosity changes that affect the thickness of films between bearing surfaces, friction, control of temperature, and energy consumption.

## NO WORMHOLING OR CHANNELING

OEI filters eliminate the opportunity for wormholing and channeling that conventional paper, fiberglass, and polymer media filter elements are subject to.

Wormholing: when wear contamination punctures the filter media.

Channeling: when fluid flows through punctured holes because it takes the path of least resistance.

[www.hubame.com.mx](http://www.hubame.com.mx) | [marketing@hubame.com.mx](mailto:marketing@hubame.com.mx) | Teléfono (81) 8000 7600

**Hubame**

Distribuidor Autorizado

# MAGNETIC FILTER ELEMENT

## EFFICIENCY

Ferrous Contamination Filtration	Captures ferrous wear particles down to 4 $\mu$ and below with up to 95+% efficiency.
Non-Ferrous Contamination Filtration	Non-ferrous particles are magnetically captured because of cross-contamination. Particles become statically charged from flow velocity. This charge is a principal force of particle adhesion; iron particles contaminate non-ferrous particles by adhering to their statically charged surface. Another form of cross-contamination occurs when sub-micron iron particles embed in softer, non-ferrous particles after abrasive impact.

## OPERATING PARAMETERS

Pressure Rating	Standard	< 34.5 bar (500 psi)
	High Pressure	< 689.5 bar (10000 psi)
Temperature Rating	Standard	< 150° C (300° F)
	High Heat	< 300° C (600° F)
Flow Rate	Housing Dependent	
Bypass Setting	Continuous	

## CLEANING

Remove the magnetic filter element from the housing, then remove the contamination with a lab cloth/ non-fiber cloth that absorbs the contamination. Save the cloth in a sample bag to send for analysis.

Use the magnetic filter element as a predictive maintenance tool by removing contamination with a lab cloth or rubber glove and depositing it into a sample jar. Send the contamination for analysis to determine the source of equipment component wear and prevent system failure.

## MATERIALS

Magnetic Filter Element	Rare-earth magnets are configured in a patented radial field design
Casing	Stainless Steel

## LIMITED WARRANTY

Magnetic Filter Element	3 years
-------------------------	---------

## SERVICE LIFE

Magnetic Filter Element	18+ years
-------------------------	-----------

[www.hubame.com.mx](http://www.hubame.com.mx) | [marketing@hubame.com.mx](mailto:marketing@hubame.com.mx) | Teléfono (81) 8000 7600



Distribuidor Autorizado

1/2" OD X 12" L

### SPECIFICATIONS

Holding Strength	57 ft-lb
Dirt Holding Capacity	1.8 lb-lft
Length Options	9", 12", 24"

Radial Magnetic Fields (12")	10
Radial Magnetic Field Diameter	3"
Magnetic Surface Area (12")	68.7 in <sup>3</sup>

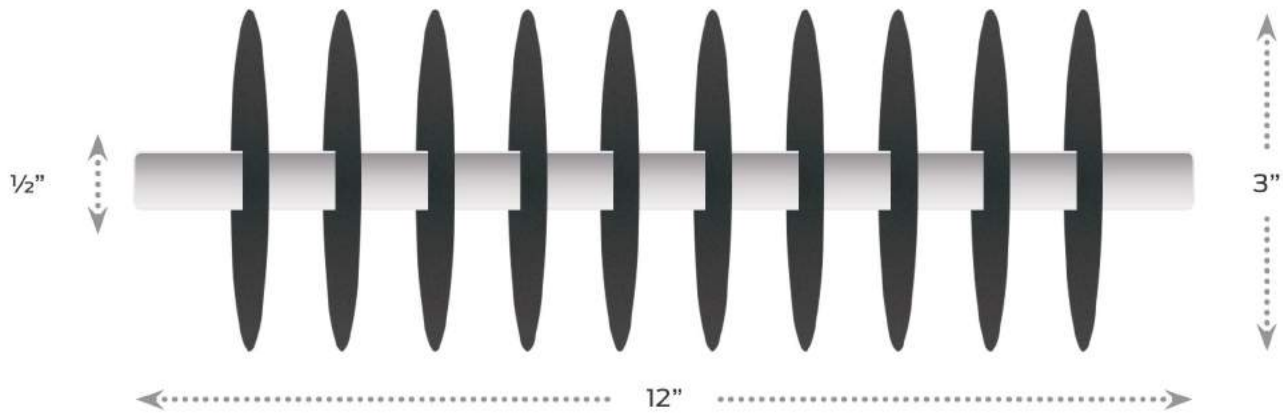

3/4" OD X 12" L

### SPECIFICATIONS

Holding Strength	123 ft-lb
Dirt Holding Capacity	3.0 lb-lft
Length Options	9", 12", 24", 36"

Radial Magnetic Fields (12")	10
Radial Magnetic Field Diameter	4"
Magnetic Surface Area (12")	125.2 in <sup>3</sup>

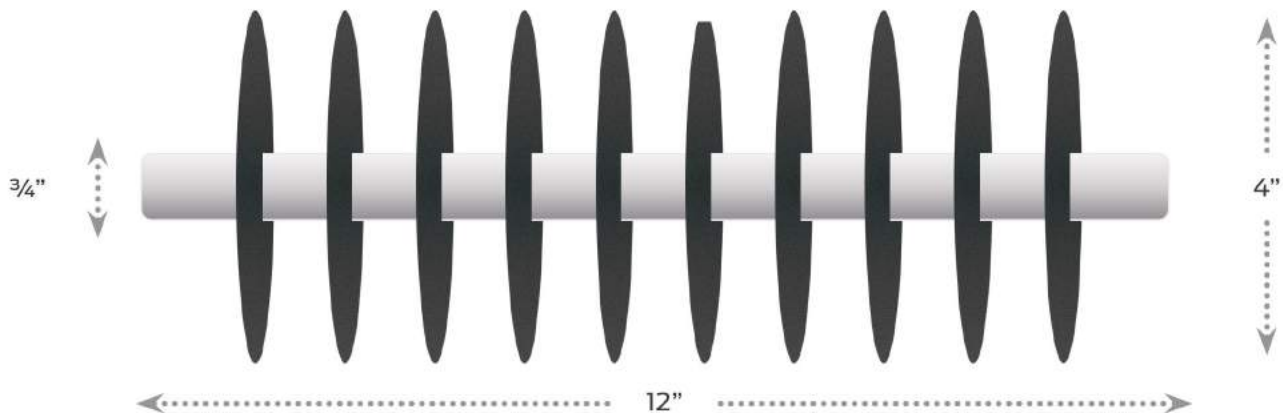

[www.hubame.com.mx](http://www.hubame.com.mx) | [marketing@hubame.com.mx](mailto:marketing@hubame.com.mx) | Teléfono (81) 8000 7600

**Hubame**

Distribuidor Autorizado



## 1" OD X 12" L

### SPECIFICATIONS

Holding Strength	270 ft-lb	Radial Magnetic Fields (12")	8
Dirt Holding Capacity	4.0 lb-lft	Radial Magnetic Field Diameter	6"
Length Options	9", 12", 24", 36"	Magnetic Surface Area (12")	195.5 in <sup>3</sup>

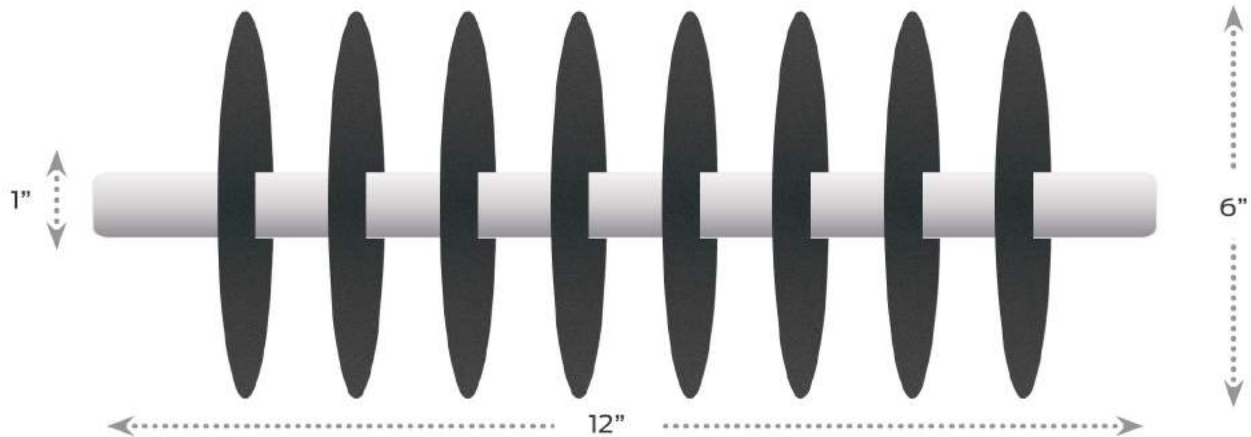

## 1 1/2" OD X 12" L

### SPECIFICATIONS

Holding Strength	500 ft-lb	Radial Magnetic Fields (12")	5
Dirt Holding Capacity	16.0 lb-lft	Radial Magnetic Field Diameter	7"
Length Options	9", 12", 24", 36"	Magnetic Surface Area (12")	328.7 in <sup>3</sup>

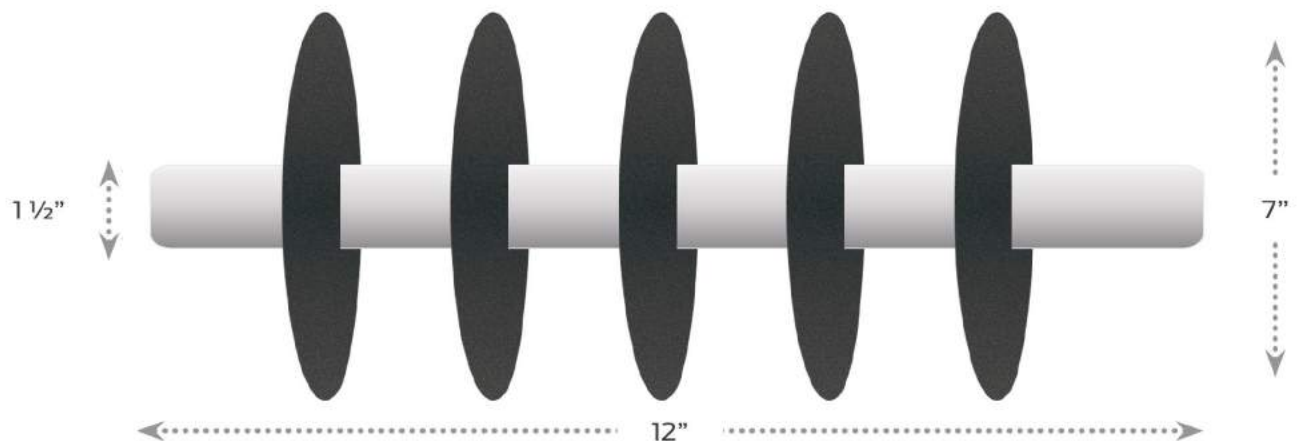



2" OD X 12" L

### SPECIFICATIONS

Holding Strength	740 ft-lb	Radial Magnetic Fields (12")	5
Dirt Holding Capacity	31.3 lb-lft	Radial Magnetic Field Diameter	8"
Length Options	9", 12", 24", 36"	Magnetic Surface Area (12")	420.9 in <sup>3</sup>

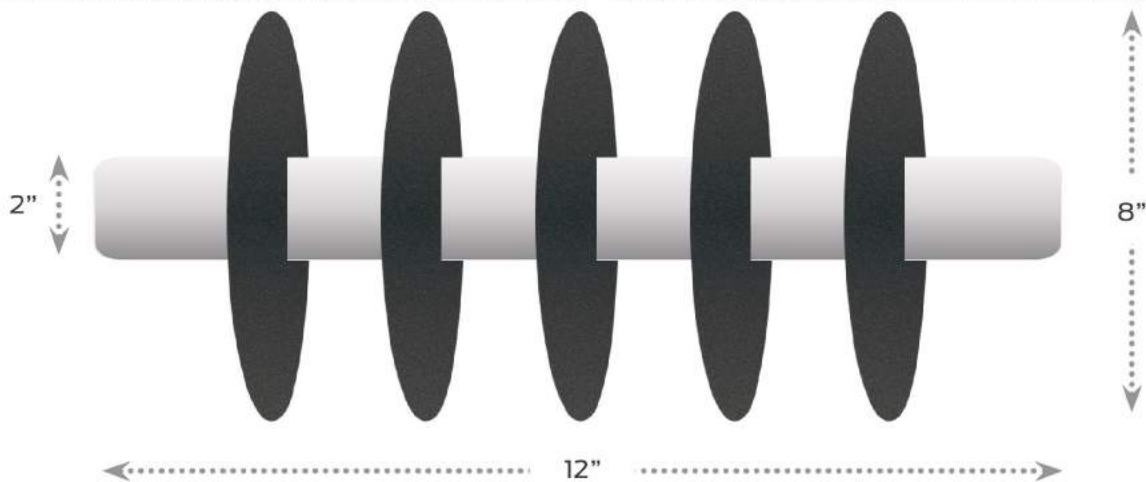

[www.hubame.com.mx](http://www.hubame.com.mx) | [marketing@hubame.com.mx](mailto:marketing@hubame.com.mx) | Teléfono (81) 8000 7600

**Hubame**

Distribuidor Autorizado

# MAGNETIC FILTER SCRUBBER - IL

## DESCRIPTION

Magnetic filter scrubbers employ a magnetic filter element in a specialty housing designed to operate with minimal flow restriction and maximum fluid exposure for high-efficiency filtration. Flow is regulated by the diameter of the inlet-outlet supply pipe as well as fluid velocity. With a billet aluminum housing, this scrubber installs inline for low-pressure, light viscosity, low-flow applications.

## BENEFITS

- » Minimal flow restriction allows for suction line installation and pump protection.
- » High holding capacity allows for extended planned maintenance periods.
- » Acts as an effective predictive maintenance tool if contamination is collected and analyzed to determine sources of equipment component wear.

FUEL

COOLANT

ENGINE OIL

CHEMICALS

HYDRAULIC FLUID

WATER

## CLEANING

Magnetic Filter Element: Remove the contamination with a lab cloth/non-fiber cloth that absorbs the contamination. Save the cloth in a sample bag to send for analysis.

Use the magnetic filter element as a predictive maintenance tool by removing contamination with a lab cloth or rubber glove and depositing it into a sample jar. Send the contamination for analysis to determine the source of equipment component wear and prevent system failure.



[www.hubame.com.mx](http://www.hubame.com.mx) | [marketing@hubame.com.mx](mailto:marketing@hubame.com.mx) | Teléfono (81) 8000 7600

# Hubame

Distribuidor Autorizado



## EFFICIENCY

Magnetic Filter Element	Ferrous Contamination	Captures ferrous wear particles down to 4 $\mu$ and below with up to 95+% efficiency.
	Non-ferrous Contamination	Non-ferrous particles are magnetically captured because of cross-contamination from static charge or embedded ferrous particles.

## OPERATING PARAMETERS

Part Number	Port Size	Housing Size	Flow Rate		Pressure Rating	Temp. rating	Magnetic filter element
			Single-pass	Multi-pass			
5IL04	¾"	2 ¼" OD x 6" H	Single-pass	2 gpm (7.6 L/min)	6.9 bar (100 psi)	105° C (221° F)	½" OD
			Multi-pass	4 gpm (15.1 L/min)			
5IL05	1"	2.4" OD x 7 ¼" H	Single-pass	3 gpm (11.4 L/min)	6.9 bar (100 psi)	105° C (221° F)	¾" OD
			Multi-pass	6 gpm (22.7 L/min)			
5IL905	¾"	2.4 OD x 9 ¼" H	Single-pass	3 gpm (11.4 L/min)	6.9 bar (100 psi)	105° C (221° F)	¾" OD
			Multi-pass	6 gpm (22.7 L/min)			

## MATERIALS

Magnetic Filter Element	Rare-earth magnets configured in a patented radial field design.	
Filter Housing, Drain Plugs, End Caps, Mounts	Standard	Billet Aluminum
	Specialty Materials	» Stainless Steel » Other alloys available
Seals	Standard Heat	Buna
	High Heat	Viton
	Sub-zero	EDPM

## INSTALLATION

Port Type	ORB
Element Clearance	Housing length + 4"

## LIMITED WARRANTY

Magnetic Filter Element	3 years
Housing and Components	1 year

## SERVICE LIFE

Magnetic Filter Element	18+ years
-------------------------	-----------

www.hubame.com.mx | marketing@hubame.com.mx | Teléfono (81) 8000 7600

# Hubame

Distribuidor Autorizado